



# Biglift 2.55 Saa 230 VW

Electro-hydraulic twin-ram lift 5.5 t with swivel arm superstructure



**VAS 782 035A | ASE78203581000:**  
**20012132-1 & 20012132-2**

Order no.	Item no.	#	Part of the approval according to order no. 20012132-1/-2:
20012132-1	21202	1	Superstructure 2.55 Saa 230 Ø 213, incl. lifting pad 11028 (135 - 195 mm), Ø 50 mm
	12564	1	VW specification VAS 782035A
	11103	1	Document holder
	11104	1	Set of 2 magnetic tool trays
	16010	4	Lifting pad extension 50 mm – Ø50 mm 1 pc.
20012132-2	11063	1	Set of cables 10 m
	10308	1	Hydraulic unit BL PD 2150 mm, stroke 1860 mm, cylinder Ø 213 mm
	12036	1	Ecological hydraulic fluid 17 ltr

The double telescopic swivel arms convince with an **unconventional lifting area**, especially suited for utility vehicles and large passenger cars.

The **internal arm locking system** installed as standard reliably protects against external influences.

The **strong 213 mm diameter cylinders** are also designed for long-lasting functionality and further round off the high quality level which ensures **low maintenance requirements**.  
Even in the event of a power blackout the lift can still be lowered without any problems thanks to the pneumatic emergency lowering system.

The Biglift 2.55 Saa 230 is perfectly completed by a **control system that is both visually and technically convincing**.

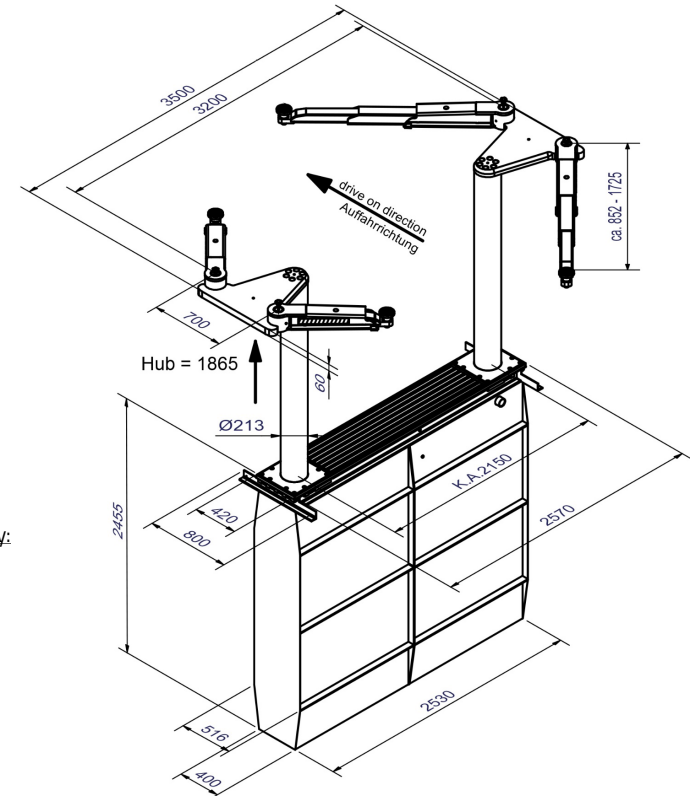

**Standard colour:**  
RAL 7012

**Options:**  
Wide range of extra pads, depending on vehicle type

**Installation variants:**  
Superstructure on floor  
Ceiling installation

Not included in the scope of approval, please order separately:

**Steel cassette:**  
Standard: painted  
Optional: hot-dip galvanized, plastic coated

Biglift 2.55 Saa 230 – VAS 782 035A | ASE78203581000