



Biglift 2.55 Saa 265 VW

Electro-hydraulic twin-ram lift 5.5 t with swivel arm superstructure



VAS 782 037A | ASE78203781000 :
20012133-1 & 20012133-2

Order no.	Item no.	#	Part of the approval according to order no. 20012133-1/-2:
20012133-1	21203	1	Superstructure 2.55 Saa 265 Ø213, incl. 4 single telescopic lifting pads 16008, Ø 50mm
	12565	1	VW specification VAS 782037A
	11103	1	Document holder
	11104	1	Set of 2 magnetic tool trays
20012133-2	16010	4	Lifting pad extension 50 mm – Ø50 mm 1 pc.
	11063	1	Set of cables 10 m
	10309	1	Hydraulic unit BL PD 2650 mm, stroke 1860 mm, cyl. Ø 213 mm
	12036	1	Ecological hydraulic fluid 17 ltr.

The double telescopic swivel arms convince with an **unconventional lifting area**, especially suited for utility vehicles and large passenger cars.

The **internal arm locking system** installed as standard reliably protects against external influences. An integrated mechanical safety ratchet offers additional safety for all working procedures.

The **strong 213 mm diameter cylinders** are also designed for long-lasting functionality and further round off high quality level which ensures **low maintenance requirements**.
Even in the event of a power blackout the lift can still be lowered without any problems thanks to the pneumatic emergency lowering system.

The Biglift 2.55 Saa 265 is perfectly completed by a **control system that is both visually and technically convincing**.

Standard colour:
RAL 7012

Options:
Wide range of extra pads, depending on vehicle type

Installation variants:
Superstructure on floor
Ceiling installation

Not included in the scope of approval, please order separately:

Steel cassette:
Standard: painted
Optional: hot-dip galvanized, plastic coated

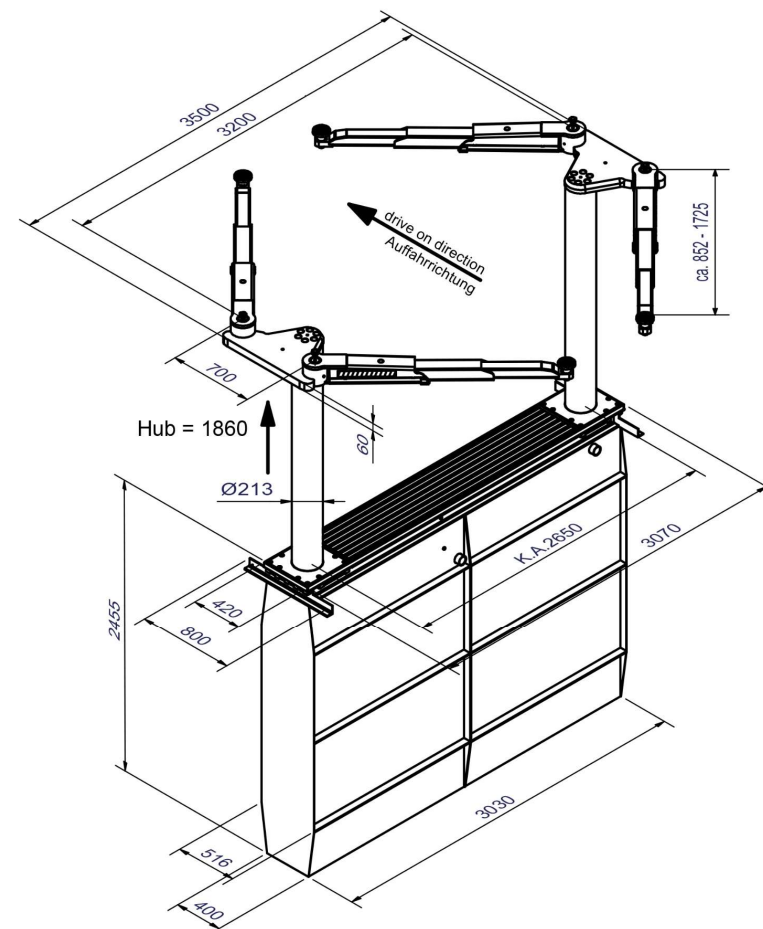

Biglift 2.55 Saa 265 – VAS 782 037A | ASE78203781000