

# Biglift 4.55 Combi

Electro-hydraulic 2x twin-ram lift, 5.5 t capacity, platforms and free-wheel lift with arms



## Application

- Check-in
- Repairs and maintenance
- Testing

## Approvals / recommendations

- Mercedes Benz
- Volkswagen Group

## Description:

### Steel cassette:

- Waterproof steel cassette

### Hydraulic unit:

- Hard-chrome plated cylinder
- Flexible synchronization and safety system
- Corrosion-free guiding elements
- Pump unit with immersed motor
- Hydraulic oil
- Pneumatic emergency lowering
- Programmable pushbutton control unit  
great stability, even with uneven weight  
distribution (all 4 cylinders in operation)

### Superstructure:

- A set of platforms with drive-on ramps and stops

### Free-wheel device Saav:

- Double telescopic arms, crosswise adjustable
- Internal arm locking system
- Low minimum height

### Standard colours

- Platforms: RAL 7016 - grey
- Saav: Base plates RAL 7016 - grey,  
arms and sliders RAL 3020 - red
- Ramps: RAL 3020 - red

## Versions:

### Steel cassette:

- Zinc-coated
- Coated

### Installation:

- Superstructure on floor
- Superstructure in floor with or  
without flush floor device

## Optional extras:

- LED-lighting set
- Large program of extra pads

**Zinc coating and special  
colours on request!**



Click the QR-Code for detailed product information.

Further Information on [www.autopstenhoj.com](http://www.autopstenhoj.com)

**AUTOPSTENHOJ GmbH**

Sandkampstraße 90  
D-48432 Rheine

+49 5971 8602-02

info@autopstenhoj.com

Technical data	
Lifting capacity	5,500 kg
Lifting height	1,895 mm
Working height	F: 2,060 mm RFH 2,195 - 2,255 mm
Cylinder diameter	8 x 140 mm
Distance between cylinders	1,240 – 1,850 mm
Lifting / lowering time (high pressure)	approx. 38 sec.
Foundation depth	2,625 mm
Pump unit	3 kW
Hydraulic oil	20 l
Voltage	230 / 400 V – 50 Hz – 16 A

Arm superstructure	
Total width	3,134 mm
Lifting pad included in the delivery	11028 (135 – 195 mm)
Min. height	165 – 220 mm
Arm length, min. - max.	725 – 1,410 mm

Platforms	
Total length	approx. 6,800 mm
Usable length of platform	5,500 mm
Wheel base	approx. 5,000 mm
Platform width	650 mm
Distance between platforms	900 mm
Drive-on height	165 mm

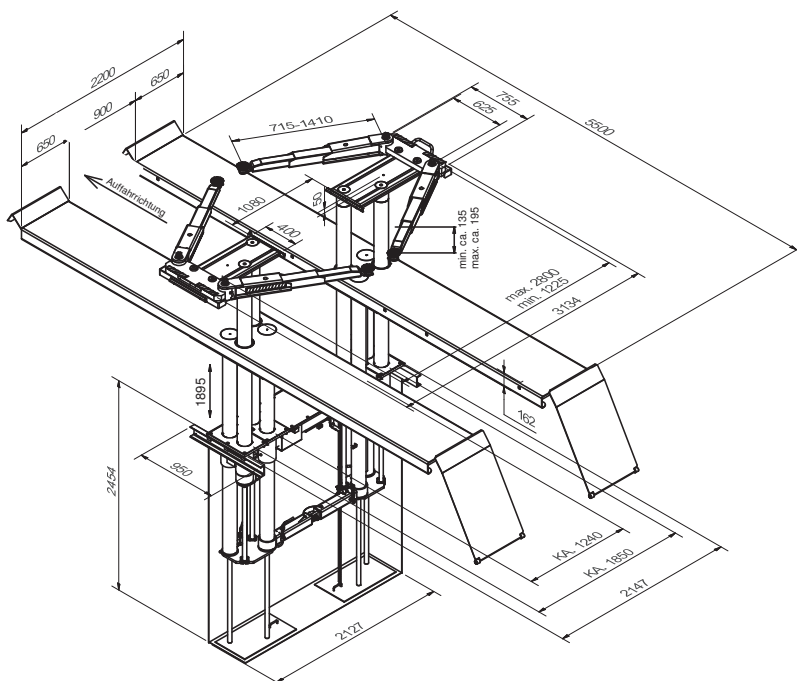

Sturdy lift with Saav free-wheel lift



LED lighting set

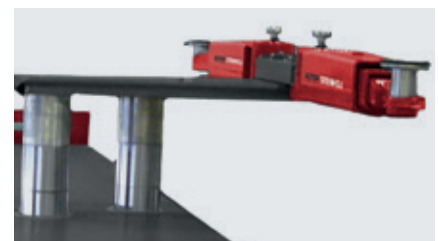

Slidable superstructure