

Sharklift 4.55

F 480/550 (KA 1550/3000)

Electro-hydraulic 4-ram lift, 5.5 t capacity, platforms



Application

- Check-in
- Repairs and maintenance
- Wheel alignment
- Testing

Approvals / recommendations

- BMW / Mini:
SHL 4.55 F 480
- Renault:
Volkswagen Group:
SHL 4.55 F 550

Description:

Steel cassette:

- Waterproof steel cassette

Hydraulic unit:

- 2 separate hydraulic units with hard-chrome plated cylinders
- Electronic synchronization between the hydraulic units and pre-programmed top stop
- Flexible synchronization and safety system
- Corrosion-free guiding elements
- Pump unit with immersed motor
- Hydraulic oil
- Pneumatic emergency lowering
- Programmable pushbutton control unit
- Air preparation unit for oil and regulated compressed air (min. 6 bar / max. 10 bar)

Superstructure:

- A set of platforms with drive-on ramps and stops
Platforms with tolerances of only max $\pm 0,5$ mm length- and crosswise
- With two recesses front and rear, as well as distance pieces covering the entire length and fixated by steel edges in sides
- Preparation for innovative air supply for jacking beam

Standard colours

- Platforms: RAL 7016 - grey
- Ramps: RAL 3020 - red
- Functional surfaces zinc-coated as standard

Versions:

Steel cassette:

- Zinc-coated
- Coated

Installation:

- Superstructure on floor
- Superstructure in floor
with or without flush-floor device

Contact us with regard to the possibilities of combining with other wheel alignment equipment!

Optional extras:

- LED-lighting set
- Precision slip plates
- Scissor jack

Special colours available on request!



Click the QR-Code for detailed product information.

Further Information on www.autopstenhoj.com

AUTOPSTENHOJ GmbH

Sandkampstraße 90
D-48432 Rheine

+49 5971 8602-02

info@autopstenhoj.com

Technical data	
Lifting capacity	5,500 kg
Lifting height	1,865 mm
Working height	2,060 mm
Cylinder diameter	4 x 140 mm
Distance between cylinders	1,550/3,000 mm
Lifting / lowering time (high pressure)	approx. 30 sec.
Foundation depth	2,625 mm
Pump unit	2 x 3 kW
Hydraulic oil	18 l
Voltage	230/400 V – 50 Hz – 16 A

Platforms	
Usable length of platform	F 480: 4,800 mm
	F 550: 5,500 mm
Wheel base	F 480: 4,150 mm
	F 550: 4,850 mm
Platform width	650 mm
Distance between platforms	900 mm
Drive-on height	195 mm

Scissor jack (Option)	
Lifting capacity	2,600 Kg
Lifting height	250 mm
Operation	air-hydraulic
Lift positions	middle / 790 – 1,460 mm

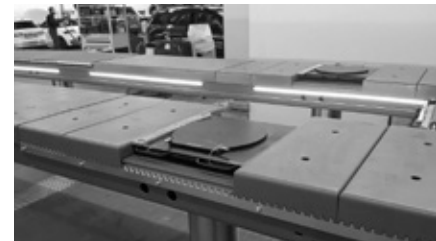
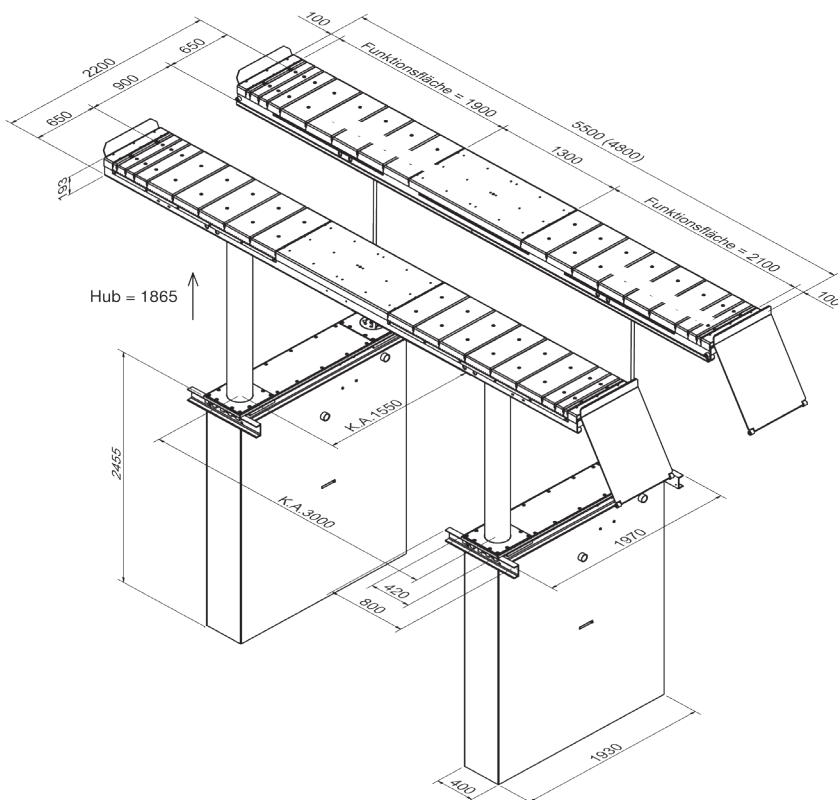

Turn table and fillers fixed



Air supply for scissor jack



Wheel alignment