

Biglift 2.55 Saa

Electro-hydraulic twin-ram lift, 5.5 t capacity, superstructure with arms



Application

- Repairs and maintenance
- Body work

Approvals / recommendations

- Volkswagen Group

Description:

Steel cassette:

- Waterproof steel cassette

Hydraulic unit:

- Hard-chrome plated cylinder
- Flexible synchronization and safety system
- Corrosion-free guiding elements
- Pump unit with immersed motor
- Hydraulic oil
- Pneumatic emergency lowering
- Programmable pushbutton control unit
- Great stability, even with uneven weight distribution; due to the cylinder diameter of 213 mm

Superstructure:

- Double telescopic arms
- Internal arm locking system
- Low minimum height

Saa 265:

- Mechanical ratchet system integrated in the hydraulic unit
- Necessary air pressure (clean, dry, lubricated): min. 6 bar / max. 10 bar

Standard colours:

- Base plate: RAL 7016 - grey
- Arms: RAL 3020 - red

Versions:

- Saa 230 & Saa 265

Steel cassette:

- Zinc-coated
- Coated
- Self-carrying (Saaa 230)

Installation:

- Superstructure on floor
- Superstructure in floor with covers
- Ceiling installation

Optional extras:

- Large program of extra pads

Zinc coating and special colours on request!



Click the QR-Code for detailed product information.

Further Information on www.autopstenhoj.com

AUTOPSTENHOJ GmbH

Sandkampstraße 90
D-48432 Rheine

+49 5971 8602-02

info@autopstenhoj.com

Technical data	
Lifting capacity	5,500 kg
Lifting height	1,860 mm
Working height	1,995 - 2,055 mm
Cylinder diameter	2 x 213 mm
Distance between cylinders	Saa 230: 2,150 mm Saa 265: 2,650 mm
Lifting / lowering time (high pressure)	approx. 45 sec.
Foundation depth	2,625 mm
Pump unit	3 kW
Hydraulic oil	17 l
Voltage	230 / 400 V – 50 Hz – 16 A

Arm superstructure	
Total width	3,500 mm
Lifting pad included in the delivery	11028 (135 – 195 mm)
Min. height	165 – 220 mm
Drive-through width	Saa 230: 1,930 mm Saa 265: 2,430 mm
Arm length, min. - max.	852 – 1,725 mm

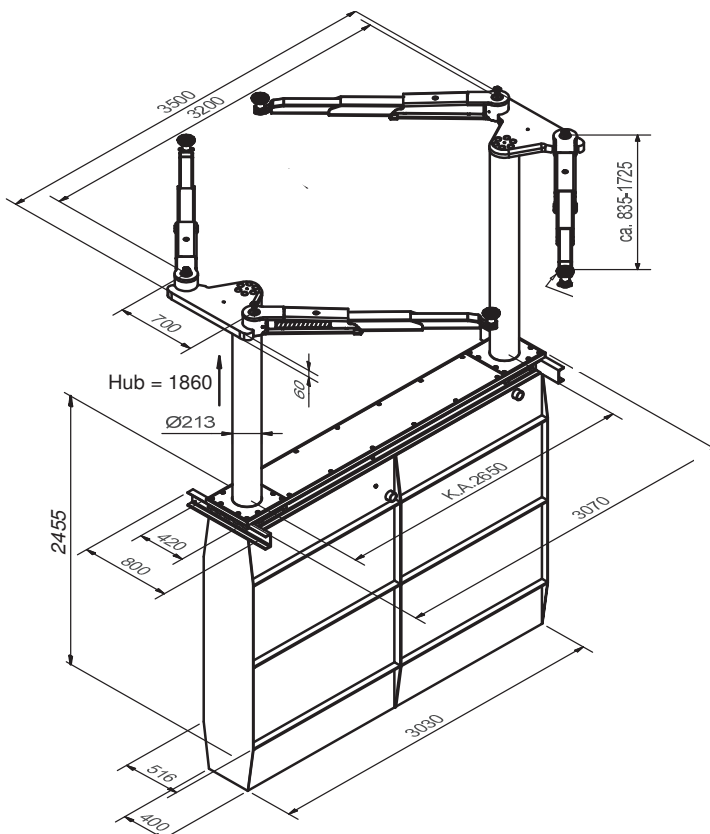

Superstructure on floor



Superstructure with lifting pads and wheel adaptors

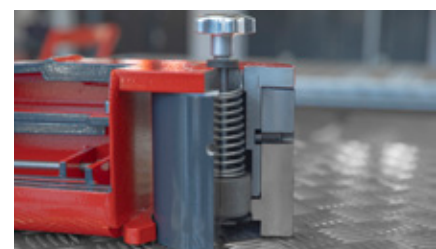

Internal arm locking system