

# Maestro 2.35 NxT

Electro-mechanical 2-post lift, 3.5 t capacity



## Application

- Repair and maintenance

## Approvals / recommendations

- Mercedes-Benz
- BMW/Mini
- Volvo

## Description:

### Posts:

- Asymmetric post installation, vehicles can be positioned in rear area of work bay, for better door-opening angle
- Very stable welded posts
- Without base frame, therefore free drive-in situation
- Two strong electric motors
- Cold-rolled spindles for high durability
- Nylon nut sets for high durability
- Carriage with 6 guiding wheels and lubrication-free roller bearings, for very low friction
- Door-stop mounted on carriage
- Obstruction system for stopping the lift when it hits an obstacle
- Pushbutton control unit with alarm signal
- Programmable limit switch for top stop and CE-stop
- Electronic synchronization through comparison of pulses on both columns

### Arms:

- Arms DT/ST: Universal lifting area from small passenger car up to VW T6 long wheel base with lifting pad type „F“
- Arms DT/DT: Universal lifting area from small passenger car up to BMW 7 series long (G12) with lifting pad type „F“
- Arms ST/ST: Lifting area adapted to work with wheel support devices
- Possibility of parallel parking of arms for easier and faster positioning of vehicles
- Arms can be opened more than 180° for better drive-in situation (+45°) for lifts installed in 90° angle to the drive lane
- Internal arm locking system, protected against moisture and dirt, with strong 360° interlocking
- Low minimum height

### Standard colours:

- Carriage and arms: RAL 3020 – red
- Posts: RAL 7016 – grey

### Versions:

- Available with different voltages
- F = flex pad
- CF = combiflex pad
- CF-08 = combiflex-08 pad
- DT/ST = double telescopic short arms in front / single telescopic long arms in rear
- DT/DT = double telescopic short arms in front and rear
- ST/ST = single telescopic long arms in front and rear

### Optional extras:

- Available with different portal heights, alternatively inground kit
- Set of expansion bolts
- LED-lighting set
- Energy set with compressed air and socket-outlet
- Extra control unit for second column
- Wheel supports
- Large program of extra pads, depending on type of vehicle

**Special colours available on request!**



Scan the QR-Code for detailed product information.

Further Information on [www.autopstenhoj.com](http://www.autopstenhoj.com)

**AUTOPSTENHOJ GmbH**

Sandkampstraße 90  
D-48432 Rheine  
+49 5971 8602-02  
info@autopstenhoj.com

**AUTOPSTENHOJ GmbH**

Barrit Langgade 188-190  
DK-7150 Barrit  
+45 76 82 13 30  
info@autopstenhoj.com

**Technical data**

Lifting capacity	3,500 kg
Lifting height	1,900 mm
Working height	1,970 – 2,035 mm + 65 mm pad extensions
Lifting / lowering time	approx. 35 sec.
Motor	2 x 2.8 kW
Voltage	3x230/400 V-50Hz - 20A



CF-pad / F-pad / CF-08 pad

**Arm superstructure**

Lifting pad included in the delivery	F: 70 - 95 mm CF: 88 - 255 mm CF-08: 95 - 255 mm
Insertion height in arm	F Premium: 44 mm
Min. height	70 mm + 65 mm pad extensions
Drive-through width	DT/DT: 2,216 mm DT/ST: 2,466 mm ST/ST: 2,466 mm
Width between posts	DT/DT: 2,509 mm DT/ST: 2,759 mm ST/ST: 2,759 mm
Total width - outer edges base plates	DT/DT 3.250 mm DT/ST: 3.500 mm ST/ST: 3.500 mm
Total height post	2,713 mm
Total height incl. Portal	3,990 - 4,350 mm
Arm length front, min. - max.	DT: 555 - 1.100 mm ST: 925 - 1.550 mm
Arm length rear, min. - max.	DT: 555 - 1.100 mm ST: 925 - 1.550 mm

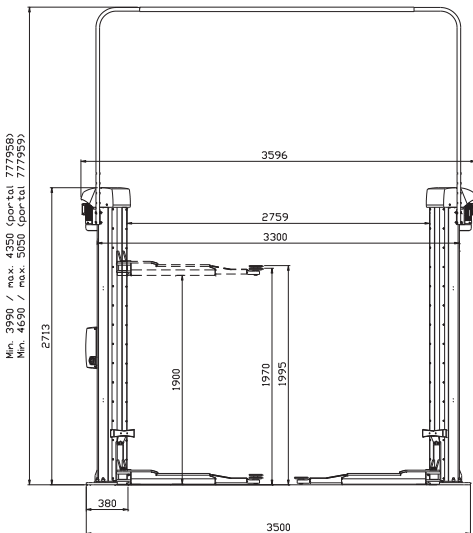

Short arm

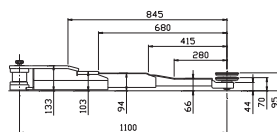

Long arm

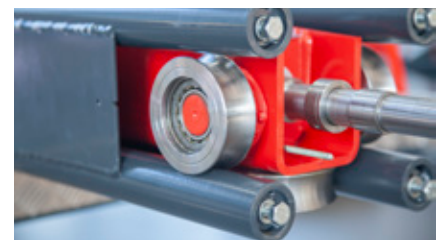
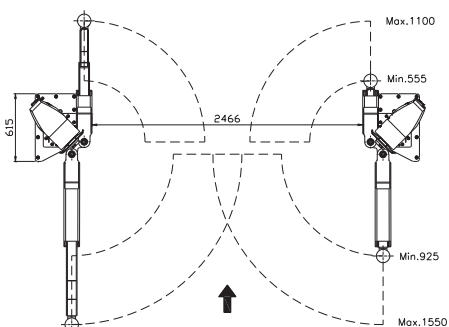
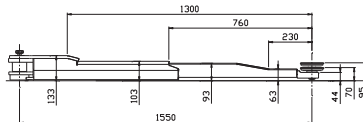

Stable, welded post

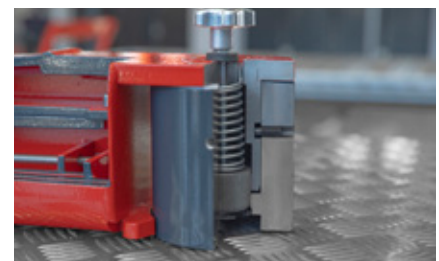

Internal arm locking system



Carriage with rollers