

MagiX 35 DS II

Electro-hydraulic double scissor lift, 3.5 t capacity



Application

- Check-in
- Repair and maintenance

Approvals / recommendations

- BMW / Mini
- Volvo
- Volkswagen Group

Description:

- Double master / slave system, therefore no compressed air and no safety ratchet necessary
- Self-locking parachute valves in cylinders against sudden increase of speed
- Control column with push buttons, integrated pump unit and alarm signal
- Electronic synchronization through photo sensor and reflector, stops lift from 50 mm difference in height
- Emergency lowering valves can manually be opened
- Sturdy scissor construction for high directional stability
- Ramps made of tear plates, for easy drive-on, also with wet wheels
- Base frame galvanized as standard
- No mechanical connection between scissor sections, therefore free gangway
- Lubrication free teflon sliding bearings in all joints
- Optimum lifting area from small passenger car up to VW T6 short wheel base / BMW series 7 long (G12)
- Low minimum height ≤ 100 mm, for perfect drive-over situation, also for flat vehicles
- No fixed drive-on direction, lift is reversible, flexible positioning of control column.
Recommended: front left side
- Rubber blocks 1 set = 4 pcs, H=40 mm, as well as hose and cable covers included in scope of delivery

Standard colours:

- Platforms & scissor: RAL 7016 – grey
- Ramps: RAL 3020 – red

Versions:

- Available with different voltages
- For surface-mounting or recession, with the same lift version
- G = galvanized platforms

Optional extras:

- Set of expansion bolts
- LED-lighting set for surface-mounted installation
- Installation frame galvanized, for recessed installation
- Set rubber blocks, 20, 40, 60, 70, 80 and 100 mm
- Hose extensions incl. covers (+ 1 meter)
- Additional long drive-over ramps for lowered cars
- Cross bar for lifting 4x4 vehicles

Special colours available on request!



Scan the QR-Code for detailed product information.

Further Information on www.autopstenhoj.com

AUTOPSTENHOJ GmbH

Sandkampstraße 90
D-48432 Rheine
+49 5971 8602-02
info@autopstenhoj.com

AUTOPSTENHOJ GmbH

Barrit Langgade 188-190
DK-7150 Barrit
+45 76 82 13 30
info@autopstenhoj.com

Technical data	
Lifting capacity	3,500 kg
Lifting height	1,923 mm
Working height	2,023 mm / 1,923 mm + Rubber pads
Lifting / lowering time	40 / 38 sec.
Pump unit	2.2 kW
Voltage	3Ph - 230/400V - 50/60 Hz

Scissor platforms	
Platform length	1,480 - 2,200 mm
Platform width	625 mm
Distance between platforms	900 mm (recommended)
Max. distance scissor - control column	2 m
Min. height	Superstructure on floor: ≤ 100 mm Superstructure in floor: 0 mm
Depth of recess	Superstructure on floor: 0 mm Superstructure in floor: 100 mm

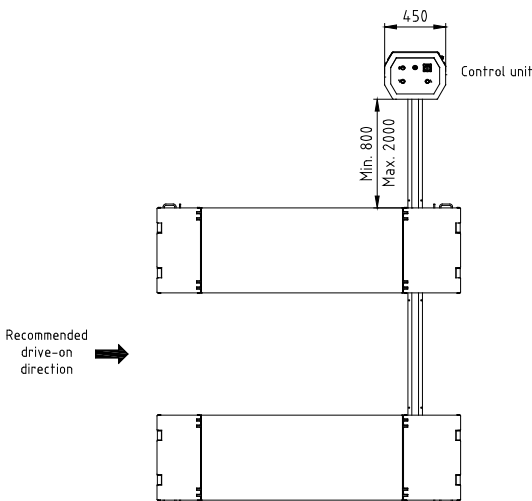
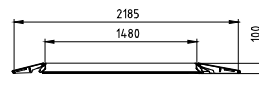
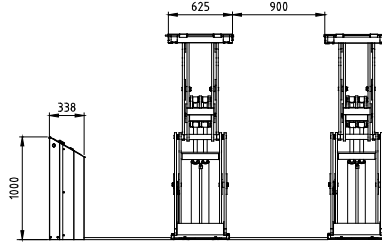
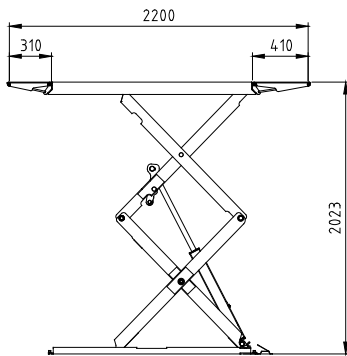

Base frame galvanized as standard



Lubrication free teflon sliding bearings in all joints



Special flat design ≤ 100 mm



Stable ramps made of tear plate, for a better drive-on situation, even in damp conditions