



Masterlift 2.35 NxT Saa & NxT TR Saa

Electro-hydraulic twin-ram lift, 3.5 t
with swivel arms

NxT Generation

NxT Generation - Inground lifts

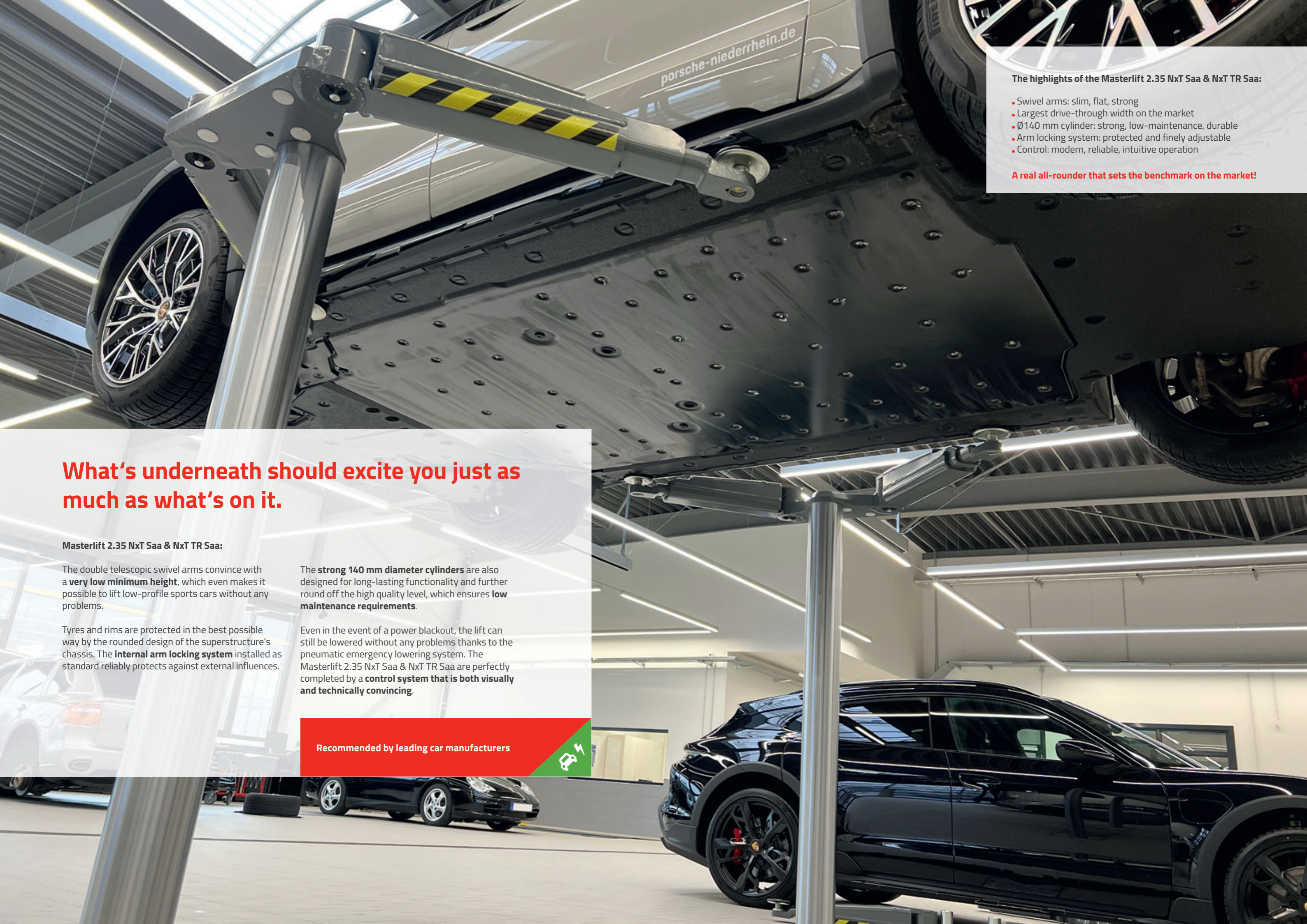

porsche-niederrhein.de

The highlights of the Masterlift 2.35 NxT Saa & NxT TR Saa:

- Swivel arms: slim, flat, strong
- Largest drive-through width on the market
- Ø140 mm cylinder: strong, low-maintenance, durable
- Arm locking system: protected and finely adjustable
- Control: modern, reliable, intuitive operation

A real all-rounder that sets the benchmark on the market!

What's underneath should excite you just as much as what's on it.

Masterlift 2.35 NxT Saa & NxT TR Saa:

The double telescopic swivel arms convince with a **very low minimum height**, which even makes it possible to lift low-profile sports cars without any problems.

Tyres and rims are protected in the best possible way by the rounded design of the superstructure's chassis. The **internal arm locking system** installed as standard reliably protects against external influences.

The **strong 140 mm diameter cylinders** are also designed for long-lasting functionality and further round off the high quality level, which ensures **low maintenance requirements**.

Even in the event of a power blackout, the lift can still be lowered without any problems thanks to the pneumatic emergency lowering system. The Masterlift 2.35 NxT Saa & NxT TR Saa are perfectly completed by a **control system that is both visually and technically convincing**.

Recommended by leading car manufacturers



Masterlift 2.35 NxT Saa

Electro-hydraulic twin-ram lift, 3.5 t with swivel arms

Synchronisation and safety via synchronisation bar

Sport (21212)
min. ~78 mm | max. ~110 mm
+ 50 mm pad extension

Universal (21214)
min. ~95 mm | max. ~174 mm

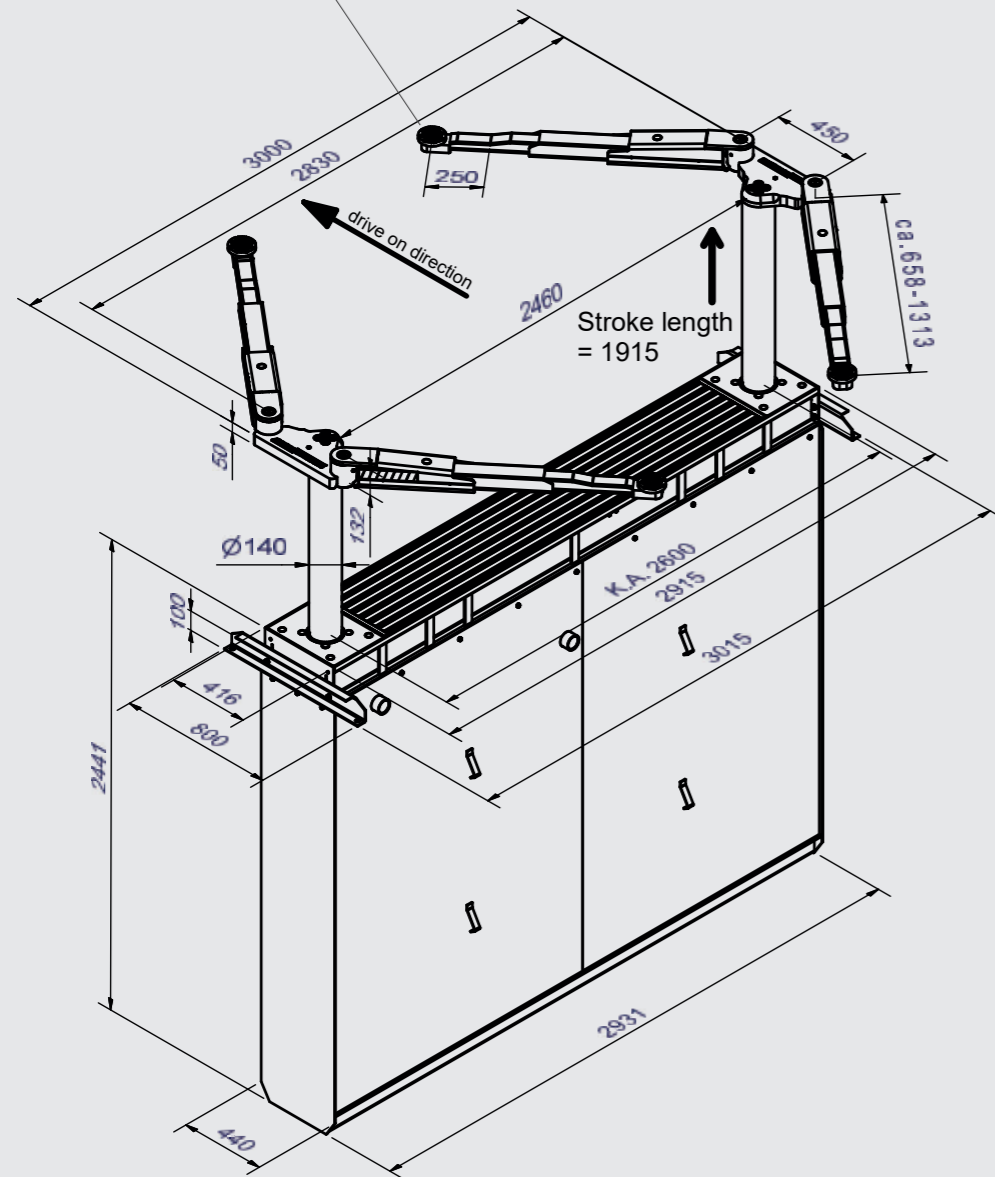

Illustrations are not binding and optional. Under reserve of dimensional, constructional and technical modifications! Validity 07/2024

Masterlift 2.35 NxT Saa

Technical data

Lifting capacity	3500 kg
Stroke length	1915 mm
Working height	Sport: 1993 - 2025 mm Universal: 2010 - 2089 mm
Cylinder diameter	2 x 140 mm
Cylinder distance	2600 mm
Lifting / lowering time	~ 30 sec.
Foundation depth	2640 mm
Pump unit	3.0 kW
Hydraulic fluid	10 l
Voltage	230/400 V / 50 Hz / 16 A

Standard colour:

- Chassis: RAL 7016
- Arms: RAL 3020 - optionally with KTL coating

Optional extras:

- Wide range of extra pads, depending on vehicle type
- Wheel support devices
- Active cassette ventilation
- Moisture monitoring in the steel cassette
- Special colours

Variants:

- Self-supporting design, without load on the bottom of the cassette
- Floor-standing design

Arm superstructure

Total width	3000 mm
Lifting pad included in the delivery	Uni: 16007 95 - 174 mm Sport: 16006 78 - 110 mm
Drive-through width	2460 mm
Min. height	Uni 95 - 174 mm Sport: 75 - 110 mm + 50 mm height extension
Arm length, min. - max.	658 - 1313 mm
Arm insertion height	55 mm

Installation variants:

- On-floor installation
- Recessed installation
- Ceiling installation

Frame:

- Standard: completely hot-dip galvanized

Sub-casing:

- Standard: painted
- Optional: hot-dip galvanized or plastic-coated

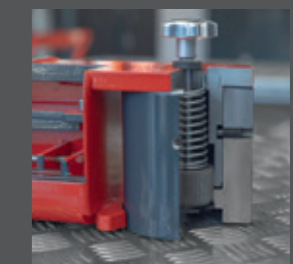
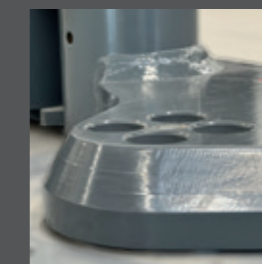

www.autopstenhoj.com



Masterlift 2.35 NxT TR Saa

Electro-hydraulic twin-ram lift, 3.5 t with swivel arms

Synchronisation and safety via toothed rack and cardan shaft

Sport (21212)
min. ~78 mm | max. ~110 mm
+ 50 mm pad extension

Universal (21214)
min. ~95 mm | max. ~174 mm

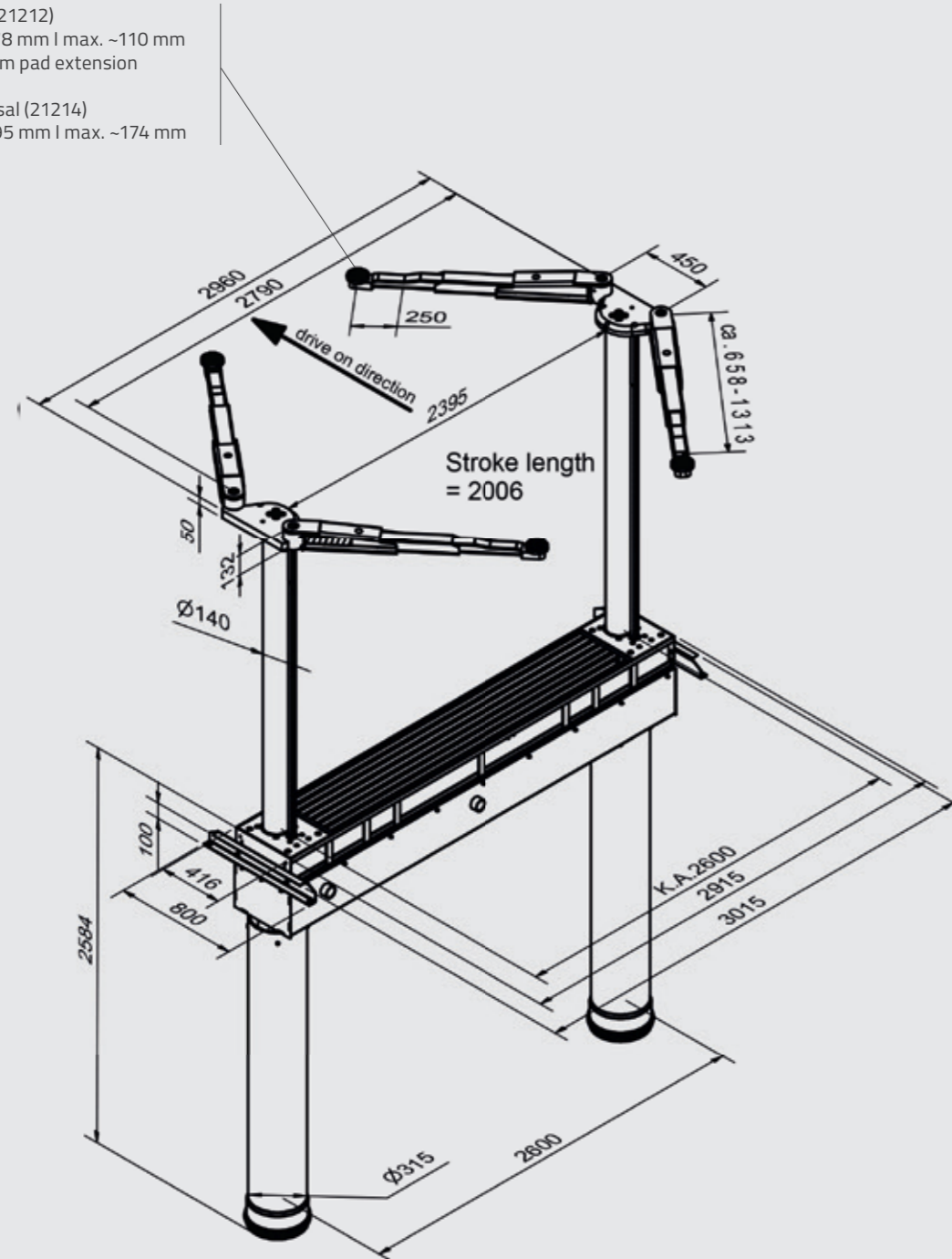

Illustrations are not binding and optional. Under reserve of dimensional, constructional and technical modifications! Validity 07/2024

Masterlift 2.35 NxT TR Saa

Technical data

Lifting capacity	3500 kg
Stroke length	2006 mm
Working height	Sport: 2084 - 2116 mm Universal: 2101 - 2180 mm
Cylinder diameter	2 x 140 mm
Cylinder distance	2600 mm
Lifting / lowering time	~ 30 sec.
Foundation depth	800 mm
Pump unit	3.0 kW
Hydraulic fluid	10 l
Voltage	230/400 V / 50 Hz / 16 A

Standard colour:

- Chassis: RAL 7016
- Arms: RAL 3020 - optionally with KTL coating

Optional extras:

- Wide range of extra pads, depending on vehicle type
- Wheel support devices
- Special colours

Standard:

- Basically self-supporting design

Arm superstructure

Total width	3000 mm
Lifting pad included in the delivery	Uni: 16007 95 - 174 mm Sport: 16006 78 - 110 mm
Drive-through width	2460 mm
Min. height	Uni 95 - 174 mm Sport: 75 - 110 mm + 50 mm height extension
Arm length, min. - max.	658 - 1313 mm
Arm insertion height	55 mm

Installation variants:

- On-floor installation
- Recessed installation
- Ceiling installation

Frame:

- Standard: completely hot-dip galvanized
- Incl. primed tube connection frame

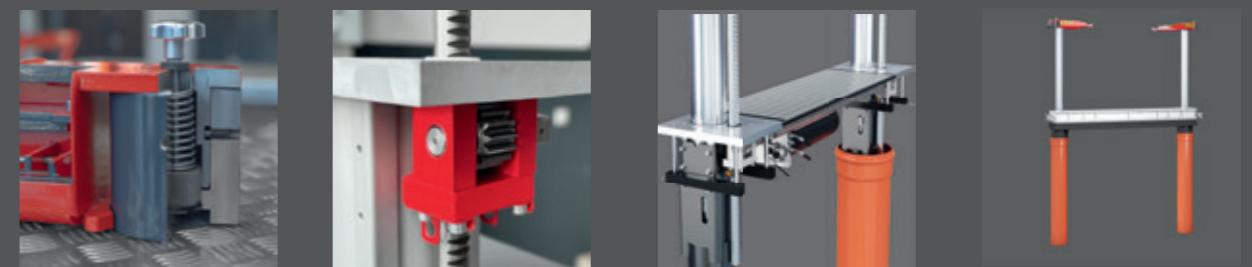

www.autopstenhoj.com



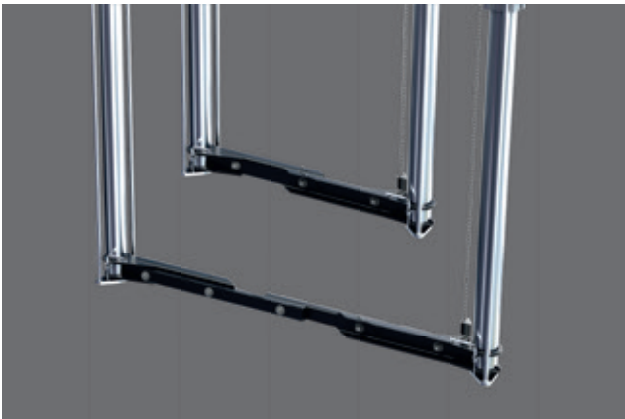

And even more highlights: Inground technology reinvented!

With the **NxT Generation** inground lifts from AUTOPSTENHOJ you experience quality at the very highest level! We have made the best even better for you!

NxT Generation inground lifts: Flexible in installation and operation, also adaptable to possible, changing requirements in the future, due to our smart clamping system.

Synchronisation takes place either via a synchronisation bar or alternatively via a toothed rack. We achieve maximum stability through strong 140 mm cylinders and through our new aluminium guidance made of anodised solid material. With the new cassette cover, even strong forces acting on the cover during battery removal, for example, are safely absorbed.

The complete, sophisticated system gets by with only 10 litres of hydraulic fluid, thanks to proven high-pressure technology. Those who have the environment in mind should not disregard this fact.

The **NxT Generation inground lift** is suitable for all installation variants and thus, of course, also for self-supporting installation. The **NxT Generation inground lifts** are also always a good choice for replacement campaigns or retrofitting in third-party cassettes.

NxT Generation: Patented, flexible, modular

