



Masterlift 2.40 NxT F & Fn

Electro-hydraulic twin-ram lift,
4.0 t with platforms

NxT Generation - Inground lift

NxT Generation



The highlights of the Masterlift 2.40 NxT F & Fn:

- Stable platform construction
- OEM-tested paint structure incl. anti-slip coating
- Optimum access to the vehicle for quick work
- Comfortable lifting range for wheel-free device (Fn)
- Optional scissor jack up to 2.6 tonnes

From the pro for the pro!

What's underneath should excite you just as much as what's on it.

Masterlift 2.40 NxT F & Fn:

The Masterlift 2.40 NxT F (without wheel-free device) and Fn (with wheel-free device) each consist of two platforms in a **stable welded construction** made of bent special profiles, sandblasted, primed and painted with a high-quality anti-slip coating for a **long-lasting attractive appearance**.

Both on-floor and recessed installation - alternatively also with flush floor device - are possible.

Foldable, optional supporting legs turn this platform lift into a precise wheel alignment stand.

The wheel-free device (Fn variant) offers a convenient lifting range of 1600 - 2300 mm.

The **strong 140 mm diameter cylinders** are also designed for long-lasting functionality and further round off the high quality level, which ensures **low maintenance requirements**.

Even in the event of a power blackout, the lift can still be lowered without any problems thanks to the pneumatic emergency lowering system. The Masterlift 2.40 NxT F & Fn are perfectly completed by a **control system that is both visually and technically convincing**.

Masterlift 2.40 NxT F & Fn

Technical data

	Masterlift 2.40 NxT F	Masterlift 2.40 NxT Fn
Lifting capacity	4000 kg	4000 kg
Stroke length	1915 mm	1915 mm
Working height	2063 mm	2063 mm
Cylinder diameter	2 x 140 mm	2 x 140 mm
Cylinder distance	1550 mm	1550 mm
Lifting / lowering time	~ 30 sec.	~ 30 sec.
Foundation depth	2640 mm	2640 mm
Pump unit	3 kW	3 kW
Hydraulic fluid	ca. 10 l	ca. 10 l
Voltage	3x230/400 V - 50 Hz	3x230/400 V - 50 Hz

Platforms

Total length	~ 5725 mm	~ 5725 mm
Usable platform length	4600 mm	4600 mm
Wheel base, max.	ca. 4100 mm	ca. 4100 mm
Platform width	605 mm	605 mm
Distance between platforms	900 mm	900 mm
Drive-on height	148 mm	148 mm

Wheel-free device (Fn)

Lifting capacity	./.	3500 kg
Total length	./.	1600 - 2300 mm
Total height	./.	370 mm + rubber pads
Drive-over height	./.	30 mm
Lifting / lowering time	./.	ca. 8. sec.
Operation	./.	electro-hydraulic

Scissor jack (option) - for Fn version please also order running rails!

Lifting capacity	max. 2600 kg	max. 2600 kg
Height	250 mm	250 mm
Operation	air hydraulic	air hydraulic
Lift positions	Middle/790 - 1610 mm	Middle/790 - 1610 mm

Masterlift 2.35 NxT F & Fn

Electro-hydraulic twin-ram lift, 4.0 t with platforms

Standard colour:

- Platforms: RAL 7016
- Ramps: RAL 3020

Optional extras:

- Additional supporting legs for wheel alignment
- Aluminium covering
- Scissor jack
- Lighting
- Plug-in cross bar
- Various drive-on ramps
- Hot-dip galvanization
- xy-heads for the wheel-free device (Fn)
- Drop rails for headlight tester

Installation variants:

- On-floor installation
- Recessed installation with or without flush-floor device
- Ceiling installation
- Self-supporting installation, without load on the bottom of the sub-casing

Frame:

- Standard: completely hot-dip galvanized

Sub-casing:

- Standard: painted
- Optional: hot-dip galvanized or plastic-coated



www.autopstenhoj.com

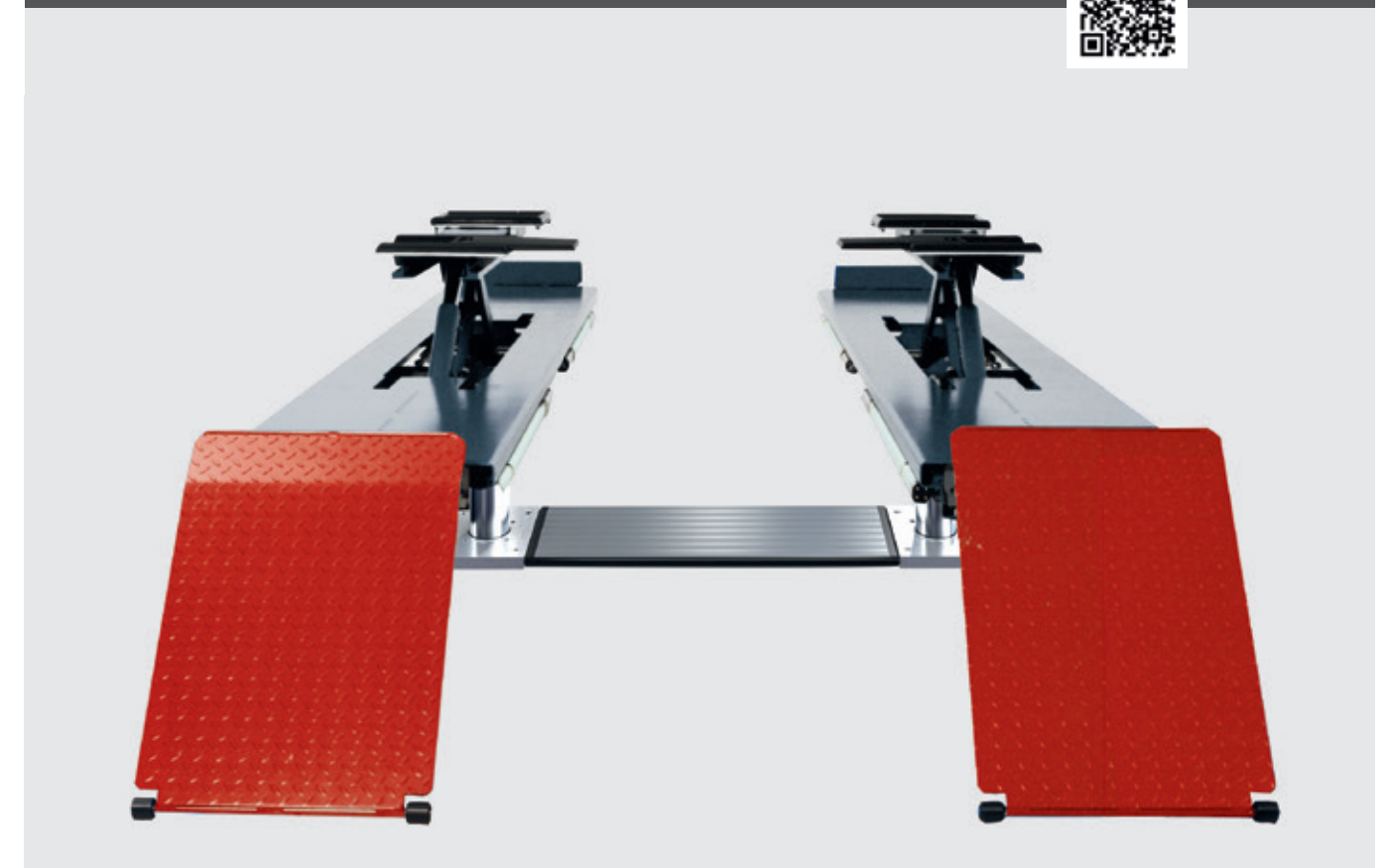

Masterlift 2.40 NxT F

Electro-hydraulic twin-ram lift, 4.0 t with platforms

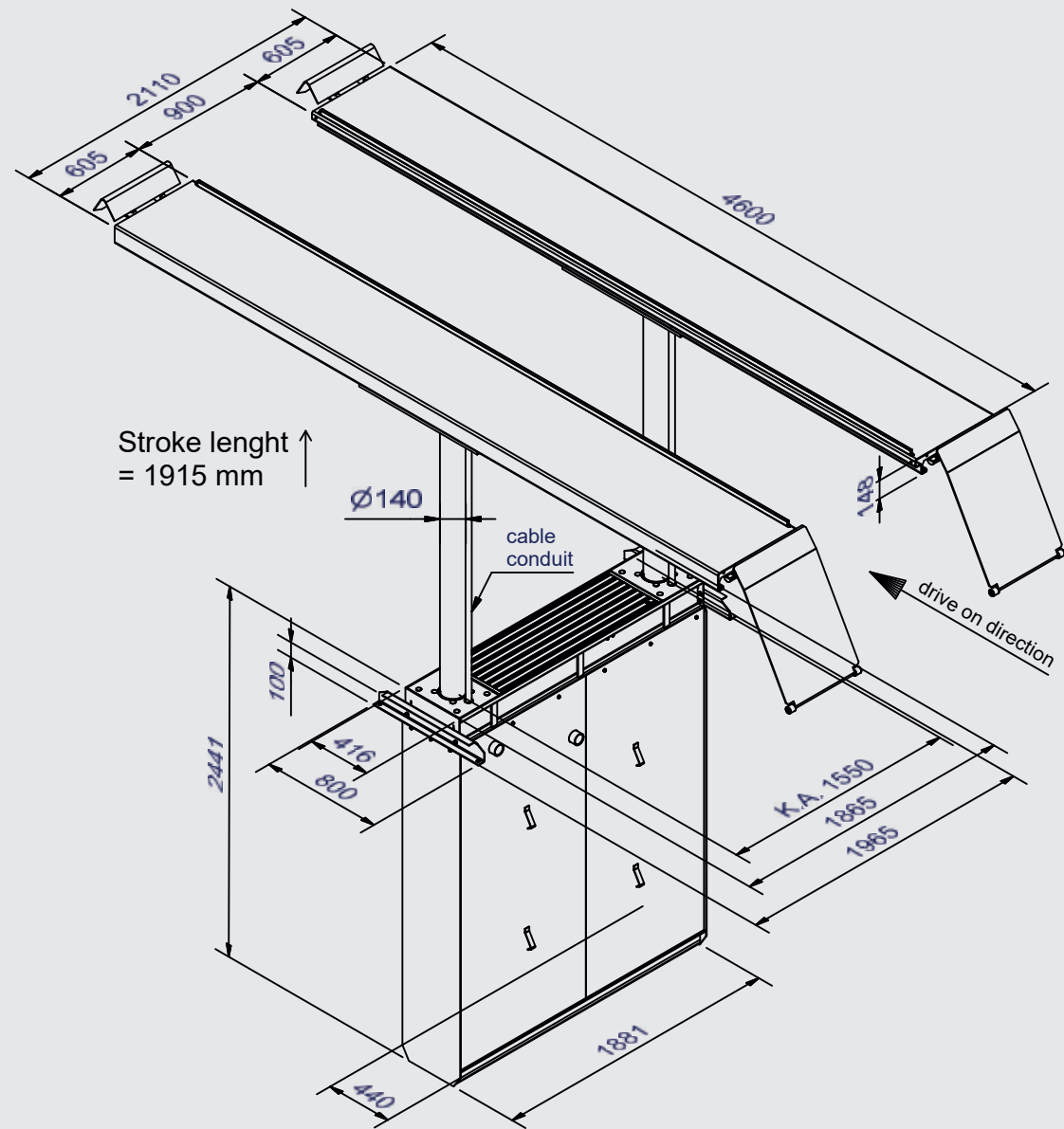

Illustrations are not binding and optional. Under reserve of dimensional, constructional and technical modifications! Validity 12/2023



Masterlift 2.40 NxT Fn

Electro-hydraulic twin-ram lift, 4.0 t with platforms and wheel-free device

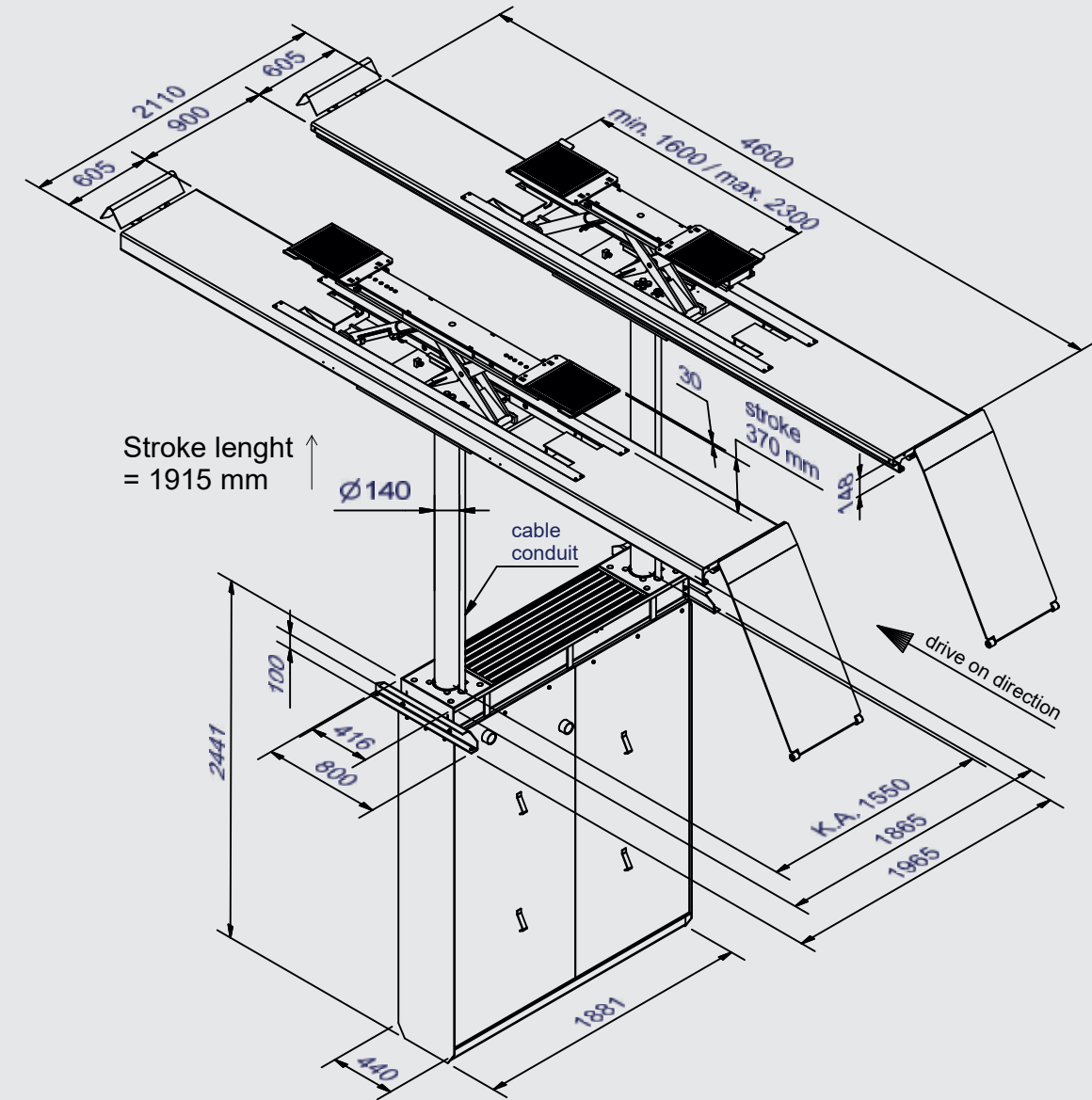

Illustrations are not binding and optional. Under reserve of dimensional, constructional and technical modifications! Validity 12/2023



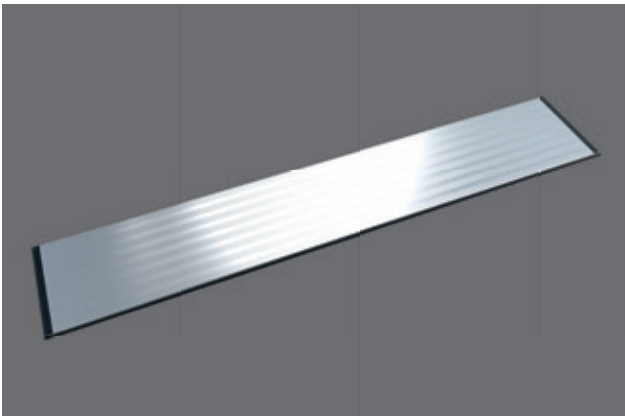

And even more highlights: Inground technology reinvented!

With the **NxT Generation inground lifts** from AUTOPSTENHOJ you experience quality at the very highest level! We have made the best even better for you!

NxT Generation inground lifts: Flexible in installation and operation, also adaptable to possible, changing requirements in the future, due to our smart clamping system.

Synchronisation takes place via a synchronisation bar.

We achieve maximum stability through strong 140 mm cylinders and through our new aluminium guidance made of anodised solid material.

With the new cassette cover, even strong forces acting on the cover during battery removal, for example, are safely absorbed.

The complete, sophisticated system gets by with only 10 litres of hydraulic fluid, thanks to proven high-pressure technology. Those who have the environment in mind should not disregard this fact.

The **NxT Generation inground lift** is suitable for all installation variants and thus, of course, also for self-supporting installation. The **NxT Generation inground lifts** are also always a good choice for replacement campaigns or retrofitting in third-party cassettes.

NxT Generation: Patented, flexible, modular.

